



SERVICE ADVISORY

Classification: HA95-03	Section: Air Conditioning	Models:
Reference: TECHNICAL BULLETIN NTB95-014	Date: February 22, 1995	

PROCEDURE FOR DETECTION OF REFRIGERANT LEAKS

APPLIED VEHICLES: All

SERVICE INFORMATION

The following procedure describes how to properly check for refrigerant leaks. Use the procedure if the amount of refrigerant in an incident vehicle is low or after R&R of air conditioning (A/C) system components.

When conducting a refrigerant leak check, use the calibrated J39400 A/C leak detector supplied to all Nissan dealers as an essential tool.

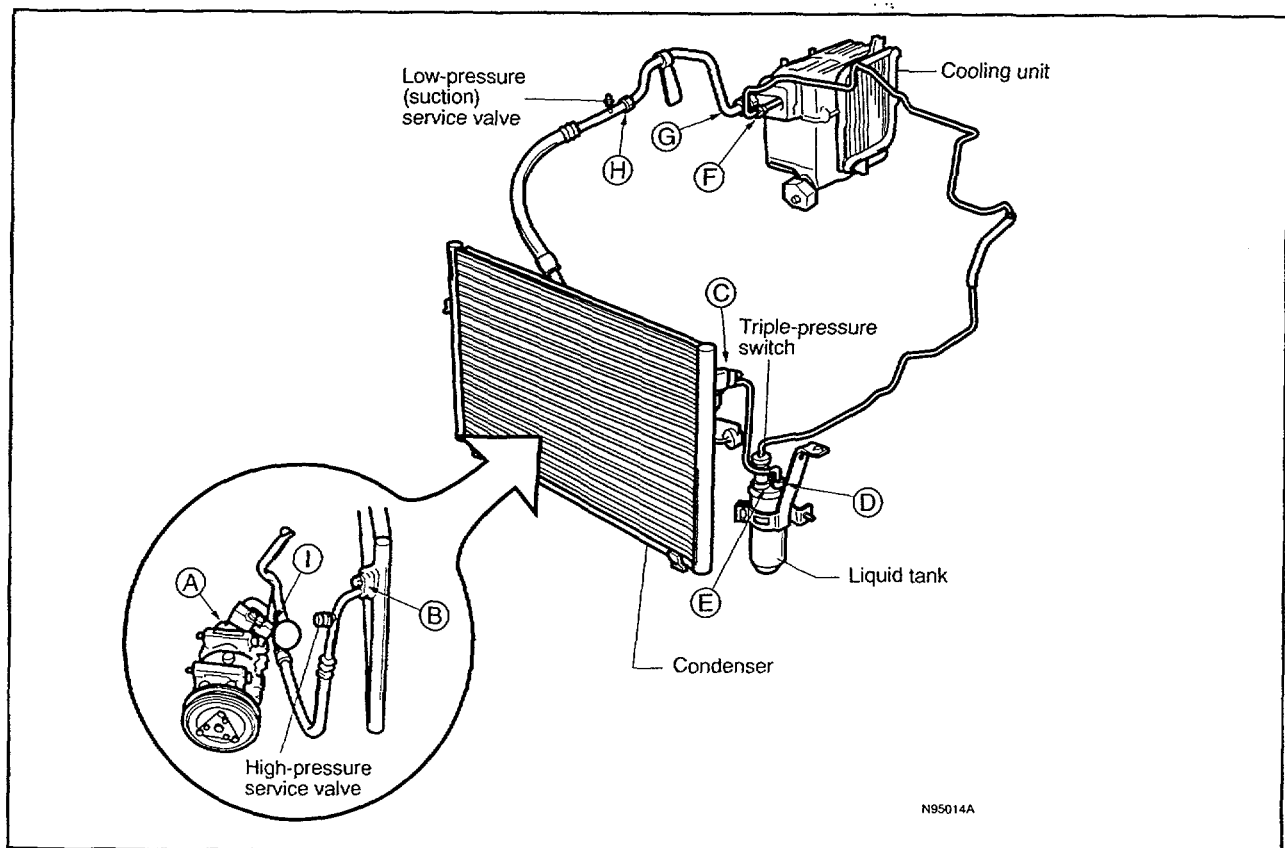

Index # 041297

Figure 1

NOTE: If possible, conduct the test in a calm area (low air/wind velocity).

1. Charge the system with the specified amount of refrigerant.

2. Conduct the test twice:

A. Engine off, check the high side to the low side

1) Run the engine with the A/C compressor ON for at least 2 minutes.

2) Stop the engine.

3) Conduct the leak test from ;the high side to the low side (A to I). See Figure 1.

B. Engine and A/C on, check both the low and high sides

With the engine and A/C on, the high side pressure increases and makes it easier to detect a leak. In addition, for the low side, some leaks could only be found when the lines/components are cold.

NOTE: Hold the detector at each connection for at least 5 seconds. This is because refrigerant is heavier than air.

3. If the J39400 leak detector detects a leak, confirm the leak with a soap and water solution to prevent misdiagnosis. Other gases in the work area or substances on the A/C components may falsely trigger the detector. Do not allow the sensor tip of the detector to come in contact with any substance. This can also cause false readings.

4. If the diagnosis shows the charge on the incident vehicle is low, complete the leak test on all system components.
Do not stop when one leak is found, continue to check for additional leaks at all system components as there may be more than one leak.

5. In cases where a component was replaced and the refrigerant charge amount was to specification (no leaks), conduct a check for refrigerant leaks around the replaced component.